

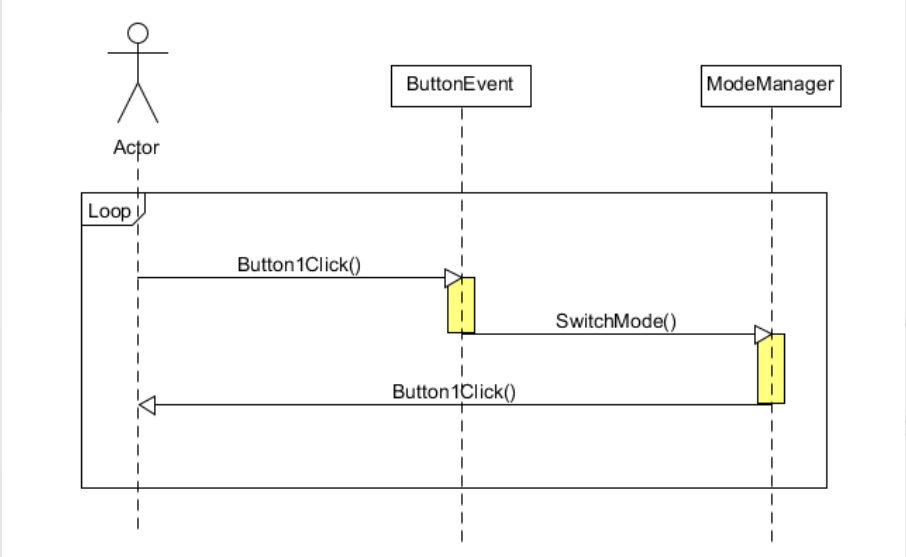

OOAD

Activity 2044. Define Interaction Diagrams

- Switch mode



Activity 2044. Define Interaction Diagrams

-SetTimeKeeping

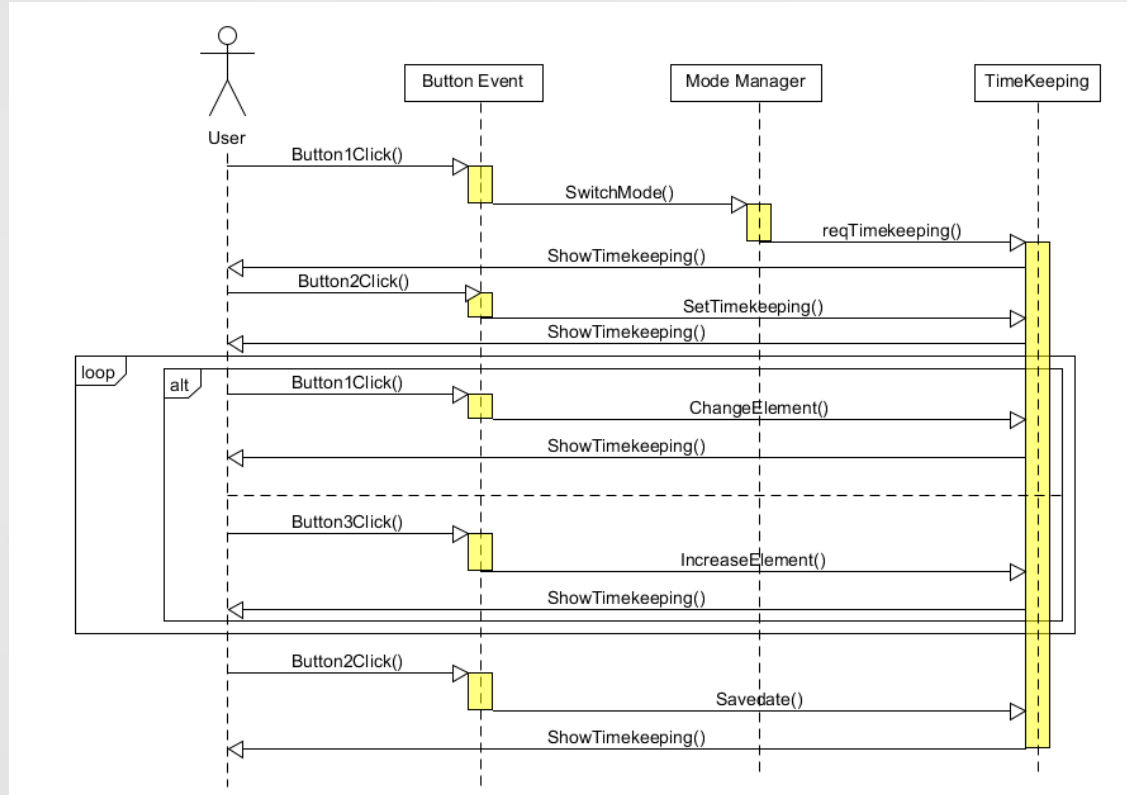

Activity 2044. Define Interaction Diagrams

- Select WorldTime

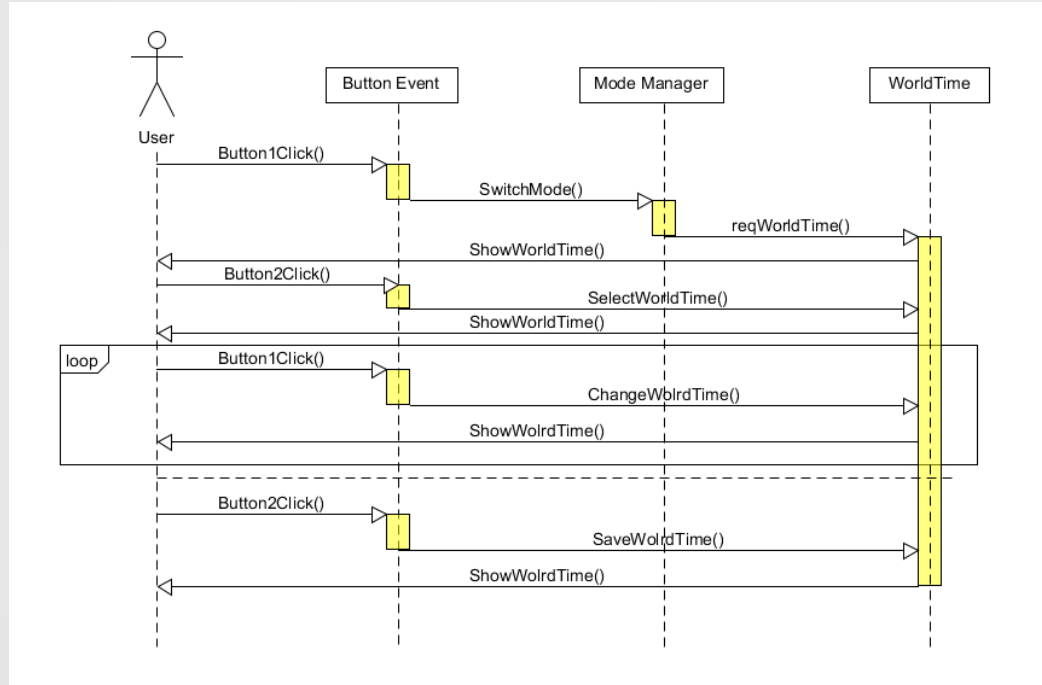

Activity 2044. Define Interaction Diagrams

- SetAlarm

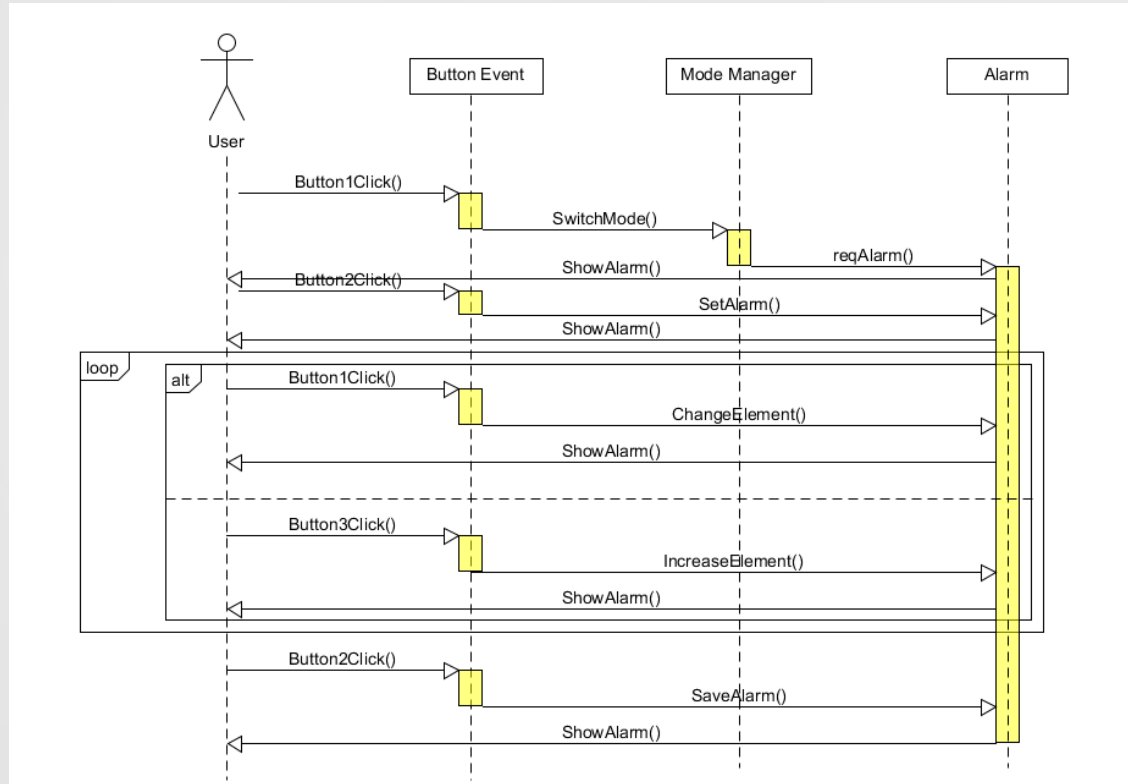

Activity 2044. Define Interaction Diagrams

- On/Off Alarm

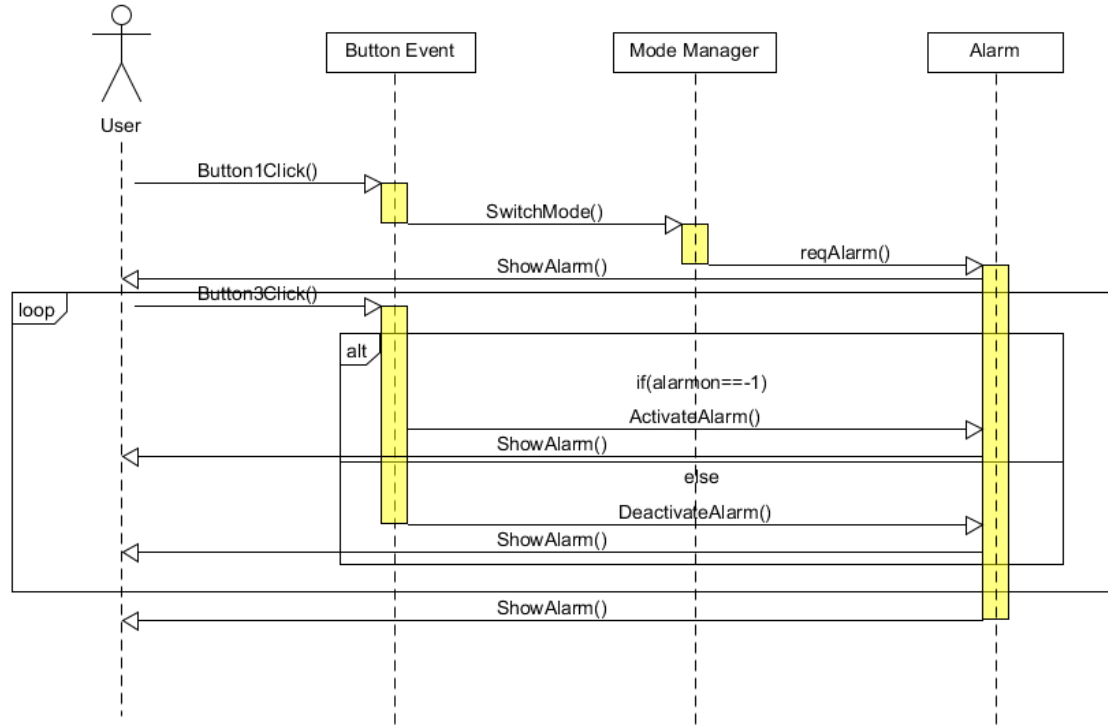

Activity 2044. Define Interaction Diagrams

- Set Timer

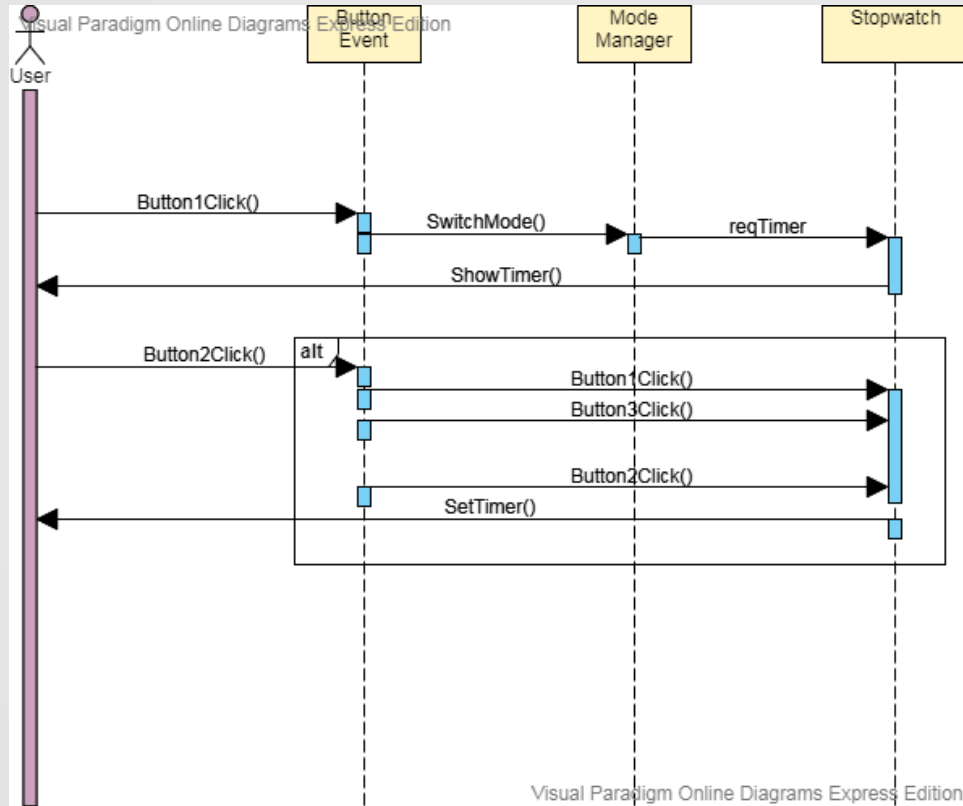

Activity 2044. Define Interaction Diagrams

- Play/Pause Timer

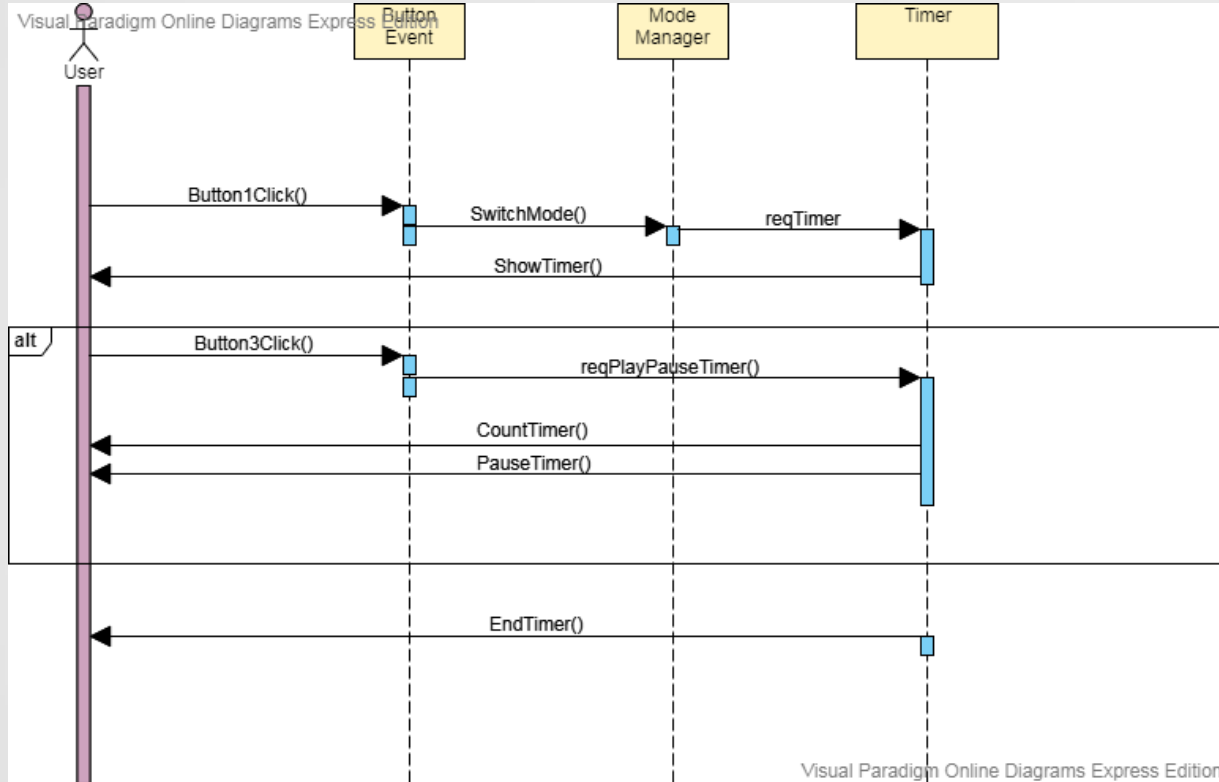

Activity 2044. Define Interaction Diagrams

- Reset Timer

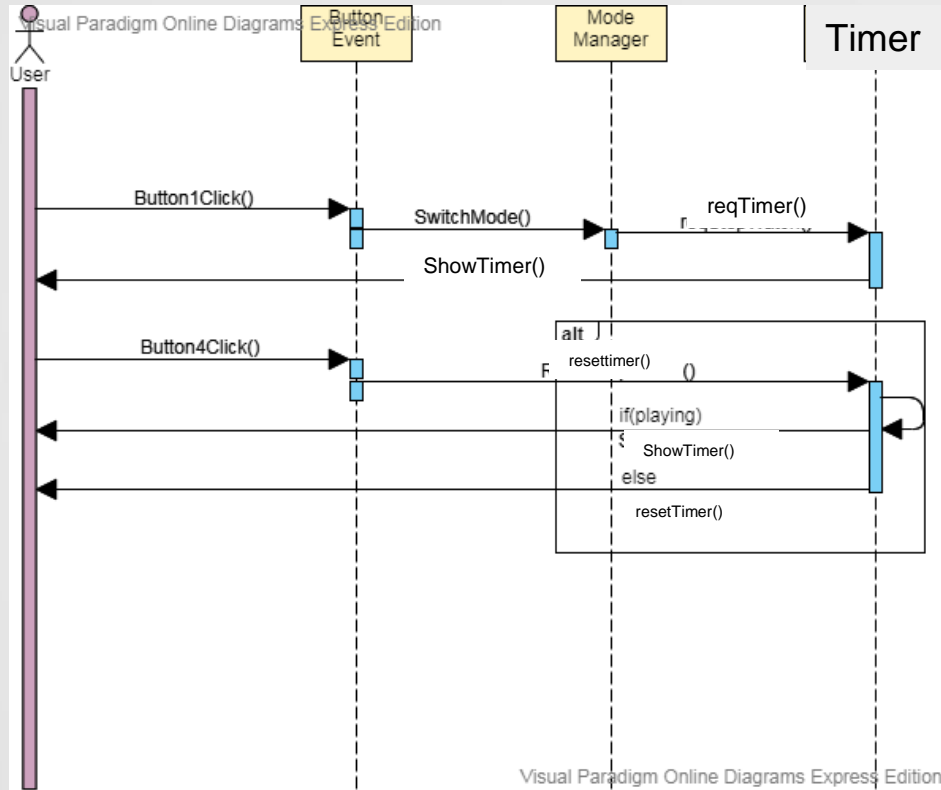

Activity 2044. Define Interaction Diagrams

- Play/Pause Stopwatch

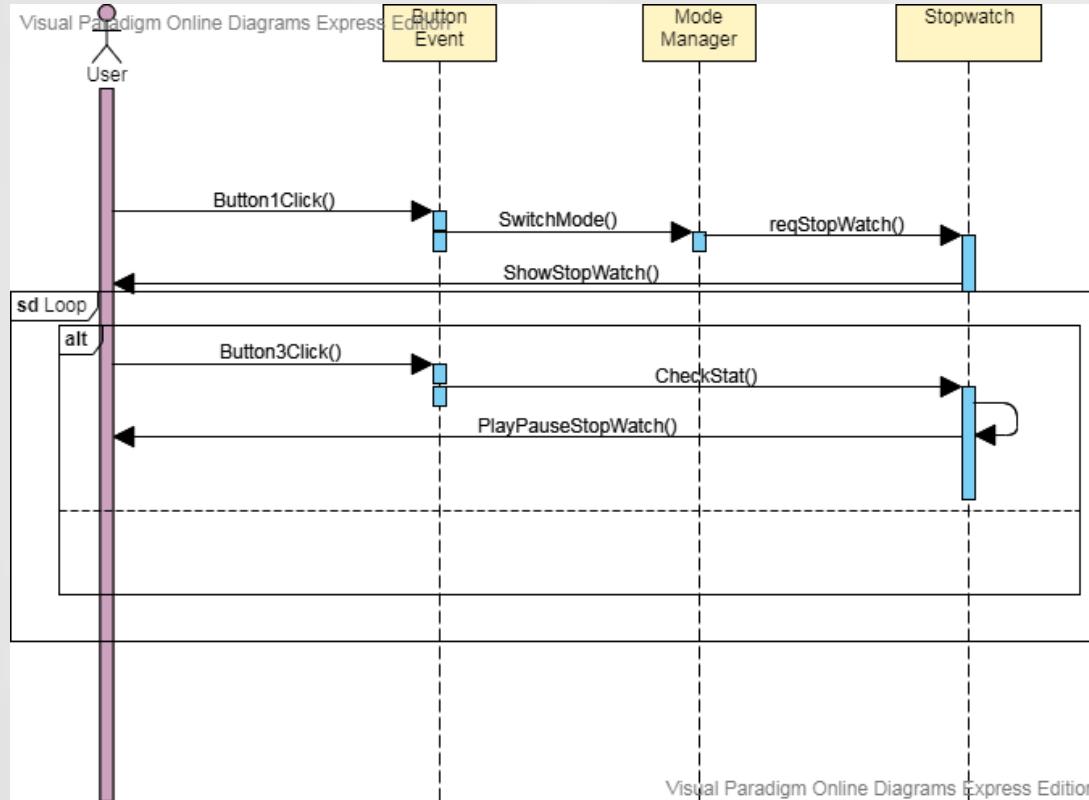

Activity 2044. Define Interaction Diagrams

- Reset stopwatch

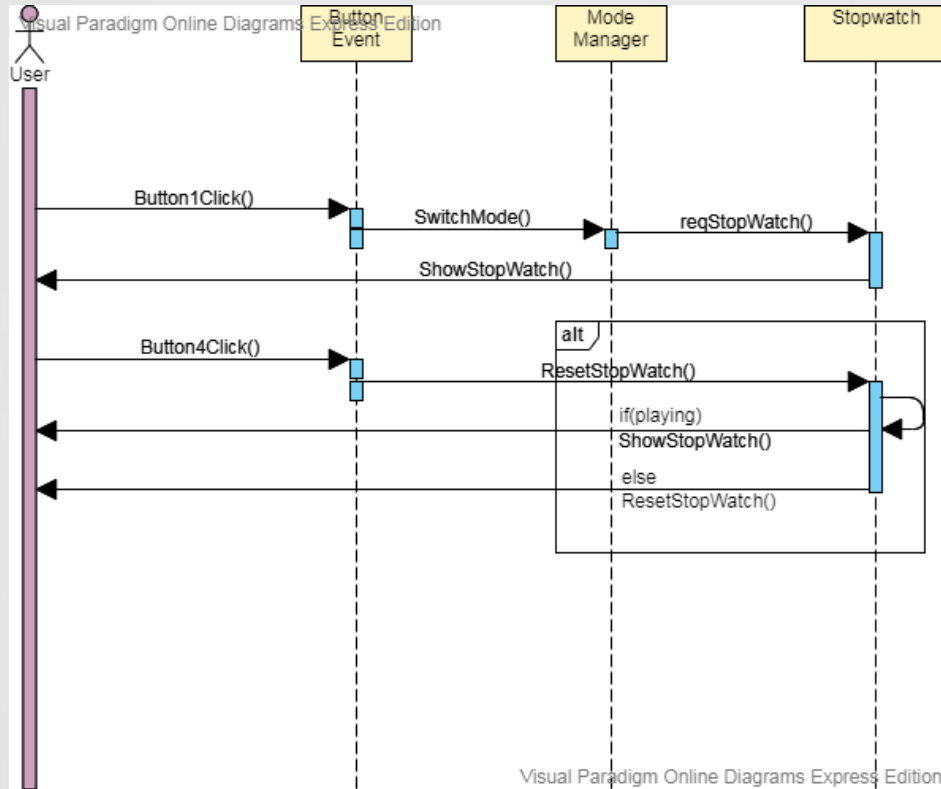

Activity 2044. Define Interaction Diagrams

- SetCycle

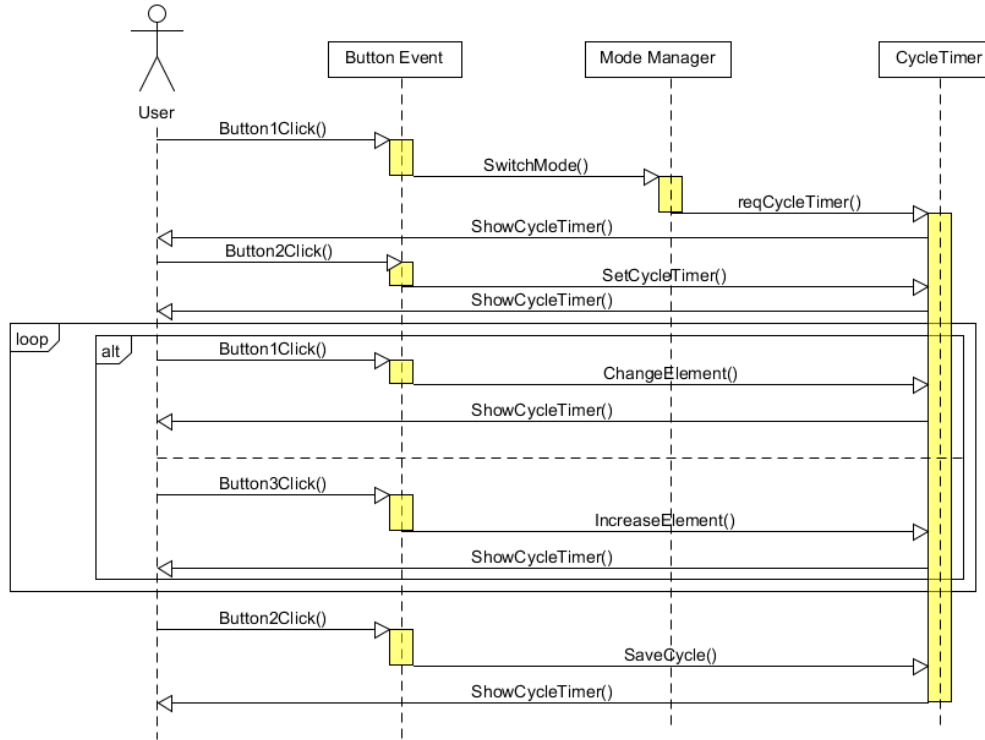

Activity 2044. Define Interaction Diagrams

- On/OffCycle

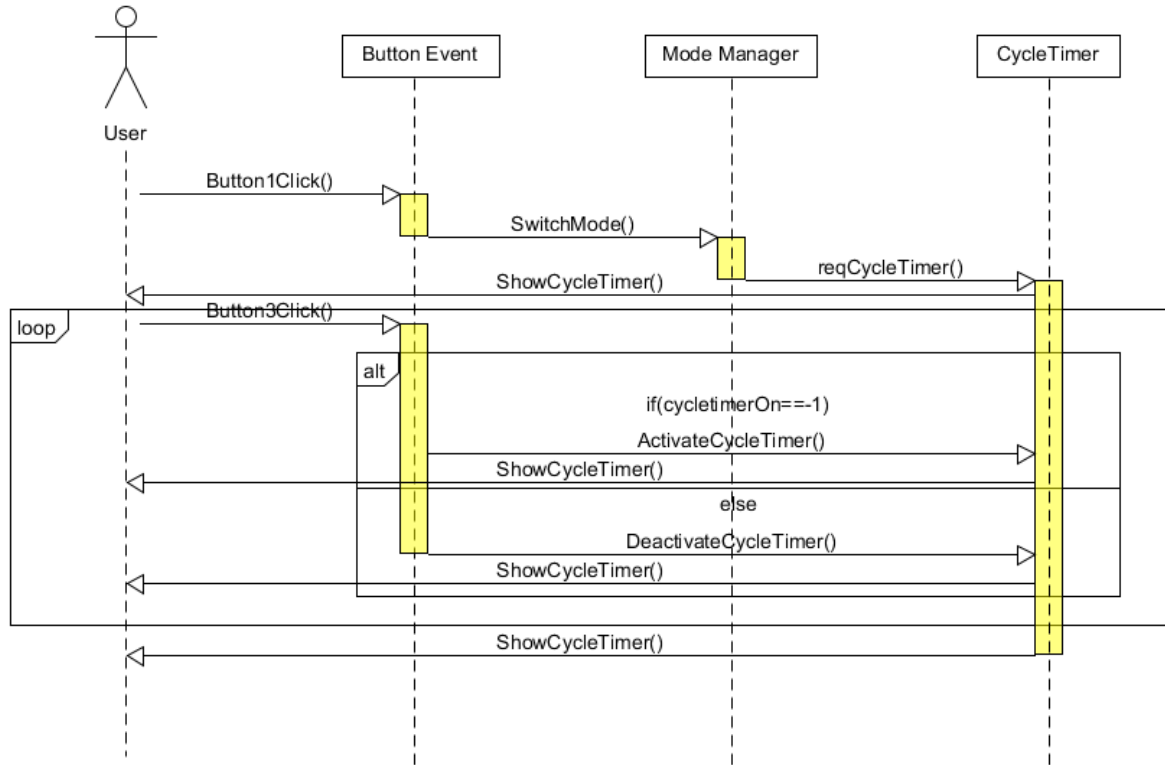

Activity 2045. Define Design Class Diagrams

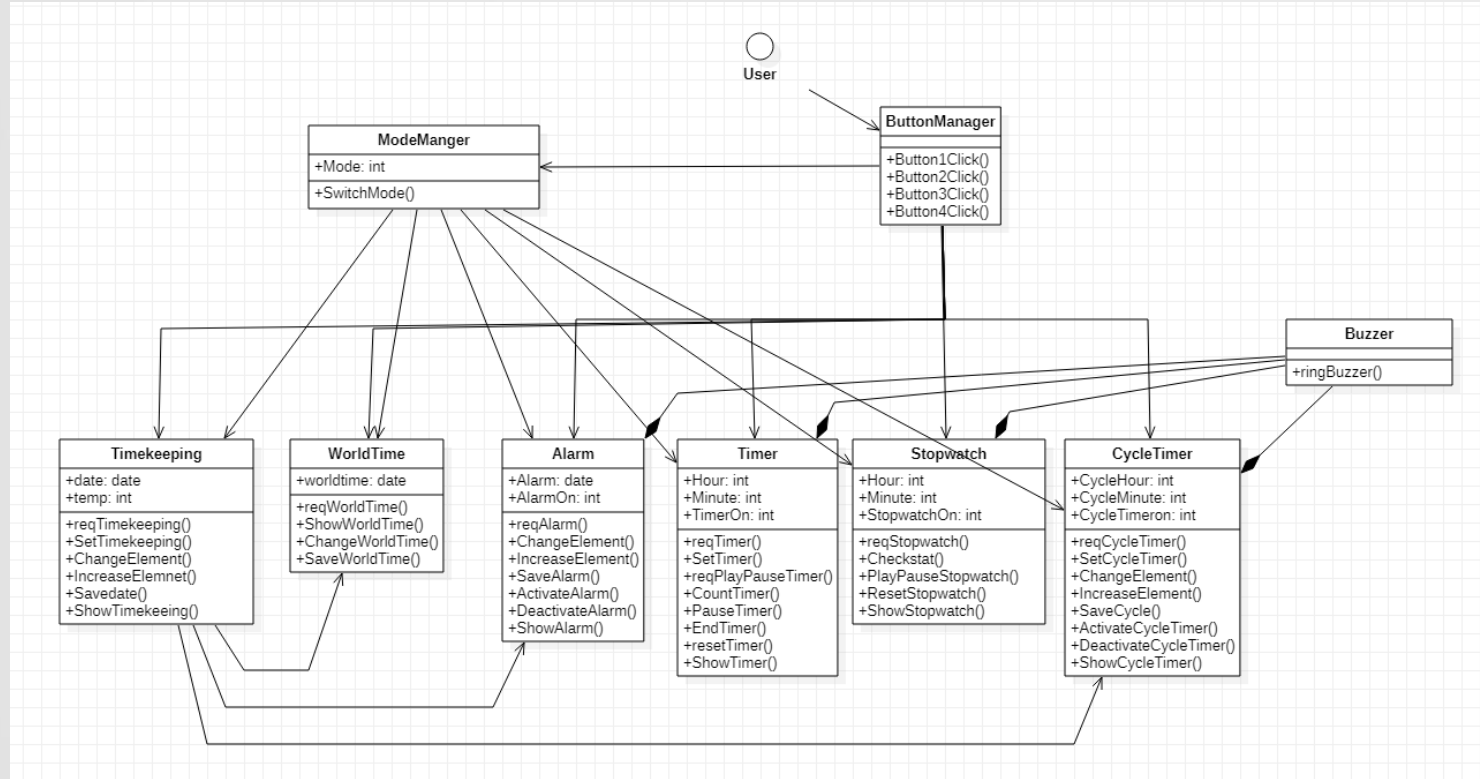

2039. Refine System Test Cases

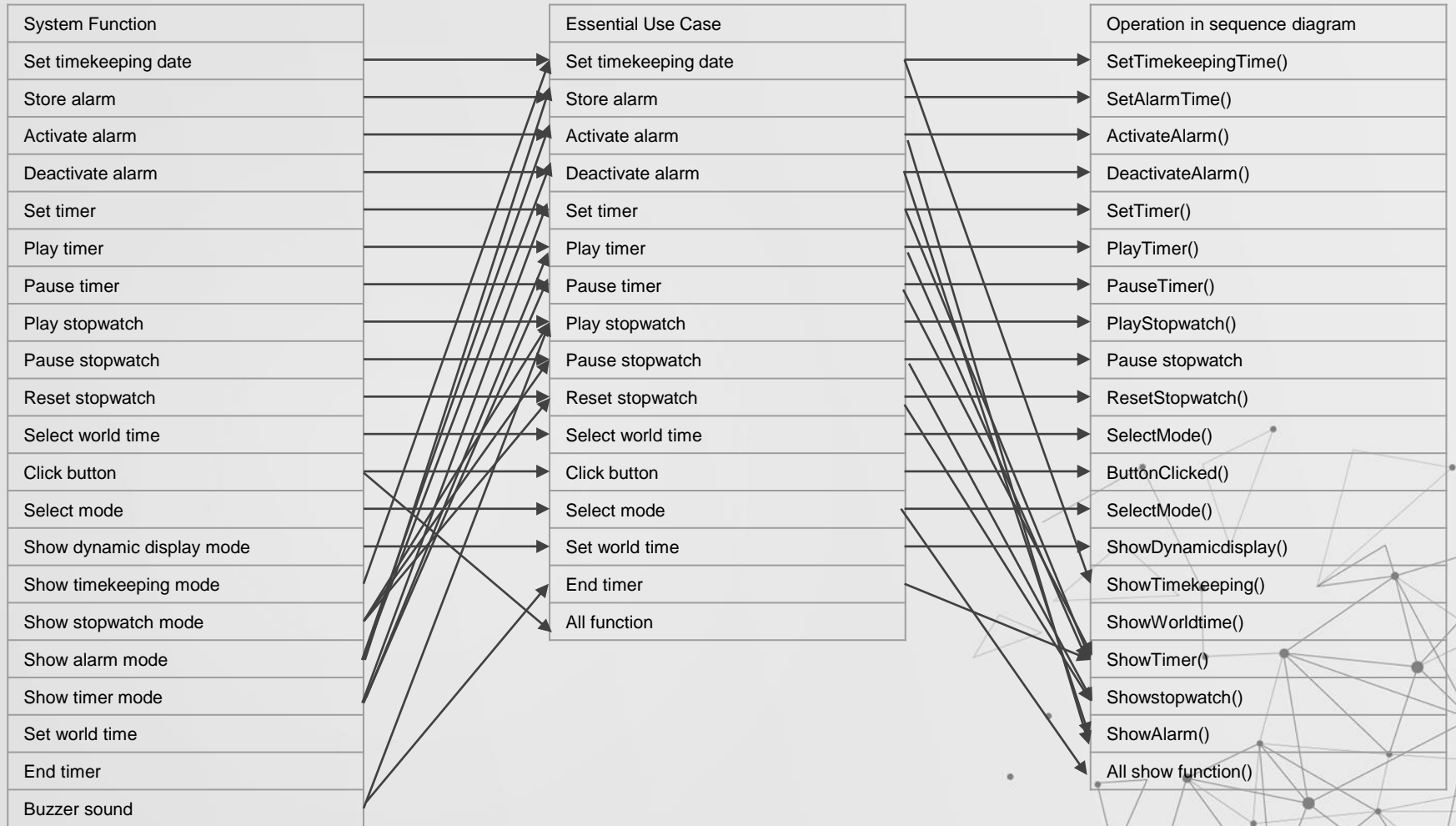

감사합니다.